

INSTRUCTION MANUAL

HGT-1T Girder Trolley 1 Tonne 64-203mm



C147

GIRDER TROLLEY



AS/NZS1418.2

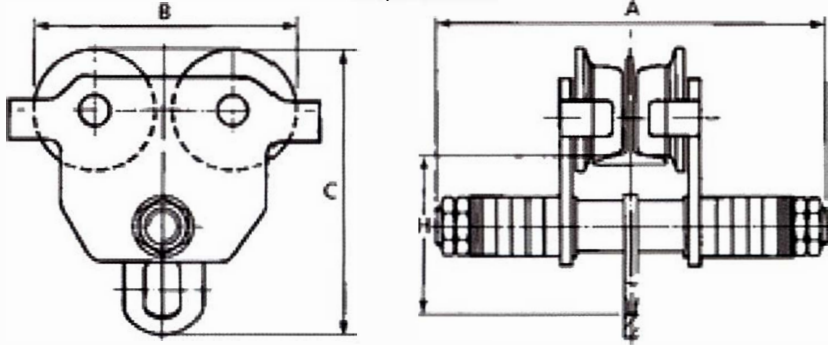

Specification

Model		HGT-1T	HGT-2T
Rated Capacity kg		1000	2000
Suit Beam Width		64-203mm	88-203mm
Dimensions mm	A	311	327
	B	246	276
	C	222	263
	H	125	150
Net weight	kg	10.5	17.5

1. The beam used with the girder trolley must be correctly installed and rated for anticipated loads.
2. Do not install trolley on beams of unknown capacity, or beams that are damaged or deformed
3. HAFCO trolleys are designed to be used with chain blocks that are the same rated capacity. Never use a chain block with a capacity greater than the capacity of the trolley.
5. The load must be centered directly under the hoist / trolley assembly.
6. Make sure load is stable and secure before moving.
7. Never raise the load more than is required to safely move it.
8. Always follow installation instructions.

GIRDER TROLLEY



Installation Instructions (refer to drawing below)

1. Instal the trolley on a beam with a min clearance (wheels to flange) of 1.6mm to max. of 2.5mm". Ref "B" on both sides of the beam.
2. To widen the trolley, remove split pins and hex nuts. Remove washer spacers from center bolt and place between hanger bracket and fixed spacer.
Note: Washer spacers must be moved in sets of two, one on either side of the hanger bracket, as the hanger bracket must always remain centered between the trolley side plates.
3. Once trolley width is spaced properly, install remaining washer spacers on the center bolt (same number on both sides) on the outside of the side plates. Install hex nuts and split pins. Do not over tighten nuts. Tighten nuts and then back nuts off to align the nut with hole in shaft for split pin. Insert split pin through each hex nut and bend one end of split pin.

